

# DLT-V73A FL Series

## Rugged RISC-Based Vehicle-Mounted Terminal



### Features

- 10.4"/12.1" color TFT XGA display
- Qualcomm Dragonwing™ octa-core 2.7GHz QCM6490
- IK08-certified touchscreen for impact tolerance and abrasion resistance
- Full IP66 rating for protection from water and dust ingress
- 5M3 shock and vibration resistance verified
- Wide operating temperature range (-10 ~ 50 °C / 14 ~ 122 °F) to withstand extreme environments
- Optional uninterruptible power supply via backup battery (up to 20 minutes of operation)
- Supports Android 14 with Google GMS & AER
- Certified with SOTI and StayLinked
- Supports Advantech DeviceOn software for remote device management

### Introduction

Advantech's DLT-V73A FL series is a RISC-based industrial grade vehicle-mounted terminal (VMT), designed for the most demanding applications to provide maximum system uptime. The slim and compact design allows it to fit into the smallest of vehicle cabinets. The compact design not only saves in-vehicle installation space, but it also minimizes obstructions to road visibility, thereby improving driving safety. The DLT-V73A FL is designed to withstand operation in extreme industrial environments, whether it is hot and humid, or cold and dry. Moreover, DLT-V73A FL supports the Android 14 operating system with Google GMS and AER, making it an ideal VMT for a wide range of smart applications, such as warehouse management, port management, heavy-duty operations, and industrial manufacturing. The integrated WLAN Kit offers excellent wireless connectivity for uninterrupted data transmission. Meanwhile, the scratch-resistant touchscreen ensures easy input and enhanced gloved operation. To sum up, Advantech's DLT-V73A FL offers a rugged VMT solution, which supports Android 14 with GMS and enterprise features and ensures easy and cost-effective system migration and device management. This makes it easy for businesses to keep up with their existing needs and remain scalable for future upgrades.

### Specifications

|                 |                                       |                                                                                                                                     |                                                |
|-----------------|---------------------------------------|-------------------------------------------------------------------------------------------------------------------------------------|------------------------------------------------|
| System          | CPU                                   | Qualcomm Dragonwing™ octa-core 2.7GHz QCM6490 8GB LPDDR4X                                                                           |                                                |
|                 | Storage                               | 128GB UFS internal, expandable 128GB or 256GB microSD card                                                                          |                                                |
| Dimensions      | DLT-V7310AP FL                        | 268 x 267 x 57 mm (10.6 x 10.5 x 2.2 inch)                                                                                          |                                                |
|                 | DLT-V7312AP FL                        | 298 x 290 x 67 mm (11.7 x 11.4 x 2.6 inch)                                                                                          |                                                |
|                 | DLT-V7312AP+ FL                       | 298 x 270 x 67 mm (11.7 x 10.6 x 2.6 inch)                                                                                          |                                                |
| Weight          | DLT-V7310AP FL                        | 3.8 kg (8.4 lb)                                                                                                                     |                                                |
|                 | DLT-V7312AP FL                        | 4.6 kg (10.1 lb)                                                                                                                    |                                                |
|                 | DLT-V7312AP+ FL                       | 4.4 kg (9.7 lb)                                                                                                                     |                                                |
| Housing         |                                       | Completely sealed, fanless design made of coated aluminum                                                                           |                                                |
| Display         | DLT-V7310AP                           | 10.4" XGA color TFT with 1024 x 768 resolution and 500 cd/m <sup>2</sup> brightness, Aspect Ratio: 4:3                              |                                                |
|                 | DLT-V7312AP / DLT-V7312AP+            | 12.1" XGA color TFT with 1024 x 768 resolution and 600 cd/m <sup>2</sup> brightness, Aspect Ratio: 4:3                              |                                                |
| Touchscreen     | PCT Projective capacitive touchscreen | DLT-V7310AP with 10" XGA display, 12 keys<br>DLT-V7312AP with 12" XGA display, 12 keys<br>DLT-V7312AP+ with 12" XGA display, 3 keys |                                                |
| Control Buttons | Front Panel 10" & 12"                 | 12 x control buttons                                                                                                                |                                                |
|                 | Front Panel 12" P+                    | 3 x control buttons                                                                                                                 |                                                |
| OS              | Operating System                      | Android 14 AOSP & Android 14 Google GMS & AER, upgradable to Android 16                                                             |                                                |
| Communication   | WLAN                                  | WLAN diversity; IEEE 802.11 a/b/g/n/ac/ax (Wi-Fi 6E)                                                                                |                                                |
|                 | WWAN, GPS                             | 5G/LTE(EU/NA separate) and GNSS(L1+L5 dual-band)                                                                                    |                                                |
|                 | LAN                                   | 1 x LAN (10/100/1000 Mbit/s)                                                                                                        |                                                |
|                 | WPAN                                  | Bluetooth 5.2                                                                                                                       |                                                |
|                 | NFC                                   | NFCIP-1 and NFCIP-2, ISO/IEC 14443, ISO/IEC 15693, MIFARE                                                                           |                                                |
| Interfaces      | Serial                                | 1 x COM RS-232: 5 V <sub>DC</sub> / 12 V <sub>DC</sub> / RI (switchable)                                                            |                                                |
|                 | USB                                   | 2 x USB-A 3.2 Gen 1, 1 x Service USB-C 3.2 Gen 1                                                                                    |                                                |
|                 | External Antenna                      | 1 x RSMA for WLAN/WWAN, 3 x SMA for WWAN, 1 x SMA for GPS                                                                           |                                                |
|                 | AddOn Module (optional)               |                                                                                                                                     | Available options (only one module at a time): |
|                 |                                       |                                                                                                                                     | 1 x USB to Serial COM RS-232                   |
|                 |                                       |                                                                                                                                     | 1 x USB to Serial COM RS-485                   |
|                 |                                       |                                                                                                                                     | 1 x USB to Serial COM RS-422                   |
|                 |                                       | 1 x USB-A 3.2 (Gen1)                                                                                                                |                                                |
|                 |                                       | 1 x LAN (10/100/1000 Mbit)                                                                                                          |                                                |
|                 |                                       | 1 x Digital I/O*                                                                                                                    |                                                |
|                 |                                       | 1 x CAN bus (CAN2.0/J1939/CAN FD)*                                                                                                  |                                                |

\* Feature under development

\*\*End date of Android security updates support: March 2028, Frequency of security updates: Every 90 days

## DLT-V73A FL Series

|                |                                            |                                                                                                                                                                         |
|----------------|--------------------------------------------|-------------------------------------------------------------------------------------------------------------------------------------------------------------------------|
| Sensors        |                                            | 1 x ambient light sensor for automatic brightness control<br>1 x Accelerometer<br>1 x Gyroscope                                                                         |
| Audio          |                                            | 2 x integrated Stereo-Loudspeaker (2 x 2.5 W)                                                                                                                           |
| Power Supply   |                                            | 12/24/48 V <sub>DC</sub> nominally Automatic Power On/Off function via vehicle ignition with optional UPS (20 minutes typical); battery life may vary according to load |
| Environmental  | IP Rating                                  | IP66 rating for the entire system                                                                                                                                       |
|                | Boot up Temperature                        | -10 ~ 50 °C (14 ~ 122 °F) for DLT-V73A FL system                                                                                                                        |
|                | Operating Temperature                      | -30 ~ 50 °C (-22 to 122 °F) for DLT-V73A FL system                                                                                                                      |
|                | Storage Temperature                        | -30 ~ 65 °C (-22 ~ 149 °F) for DLT-V73A FL system                                                                                                                       |
|                | Relative Humidity                          | 10 to 90% at 40 °C (104 °F), non-condensing                                                                                                                             |
|                | Shock/Vibration                            | 5M3 (EN 60721-3-5)<br>MIL-STD 810F (US highway truck vibration exposure)                                                                                                |
|                | Touchscreen Durability                     | IK08                                                                                                                                                                    |
| Certifications |                                            | CE Immunity Class A, Emission Class B/FCC Class B (for EU and USA), UKCA                                                                                                |
| Software       | Certified 3rd Party Software               | SOTI, StayLinked                                                                                                                                                        |
|                | Advantech Device Management Software       | DeviceOn<br>MDevice<br>MTouch<br>MBlank<br>MWedge<br>MFocus Kiosk Mode<br>Advantech Launcher<br>Advantech EMM Staging Tool                                              |
|                | DLT M-suite pre-installed software package |                                                                                                                                                                         |
|                | ▪ Free of charge                           |                                                                                                                                                                         |
|                | ▪ Features may vary by model and OS        |                                                                                                                                                                         |
|                |                                            |                                                                                                                                                                         |
|                |                                            |                                                                                                                                                                         |

## Ordering Information

### For Worldwide Models

| PN                 | Model Name      | OS             | Display   | Front Keys | Touch System     | System                                                                                                                                                                                       |
|--------------------|-----------------|----------------|-----------|------------|------------------|----------------------------------------------------------------------------------------------------------------------------------------------------------------------------------------------|
| DLV7310-9PH1GFWF00 | DLT-V7310AP FL  | Android 14 GMS | 10.4" XGA | 12 keys    | Capacitive Touch | Qualcomm® Dragonwing™ octa-core 2.7GHz QCM6490, with 8G RAM LPDDR4X, 128GB UFS, Wi-Fi 6E, BT5.2, integrated antenna, RSMA plug for external antenna connection, and integrated power supply. |
| DLV7312-9PH1GFWF00 | DLT-V7312AP FL  | Android 14 GMS | 12.1" XGA | 12 keys    | Capacitive Touch |                                                                                                                                                                                              |
| DLV7312-9QH1GFWF00 | DLT-V7312AP+ FL | Android 14 GMS | 12.1" XGA | 3 keys     | Capacitive Touch |                                                                                                                                                                                              |

## Optional Accessories

| Part Number | Description                                          |
|-------------|------------------------------------------------------|
| DL-MTKT013  | Mounting bracket mobile 15 grade fixed For V73       |
| DL-MTRM004  | RAM-Mount Set, one arm, arm length 130mm             |
| DL-MTRM001  | RAM-Mount Set, two arms, arm length 150mm            |
| 9768MDKT035 | USB3.1 Type-C to USB3.0 Type-A female OTG 15cm cable |

## Mount Kit Options

DL-MTKT013



DL-MTRM004



DL-MTRM001

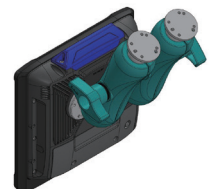

## Dimensions

Unit: mm

### DLT-V7310AP

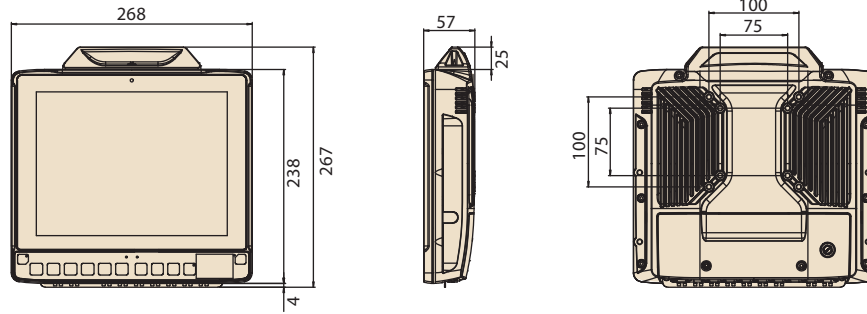

### DLT-V7312AP

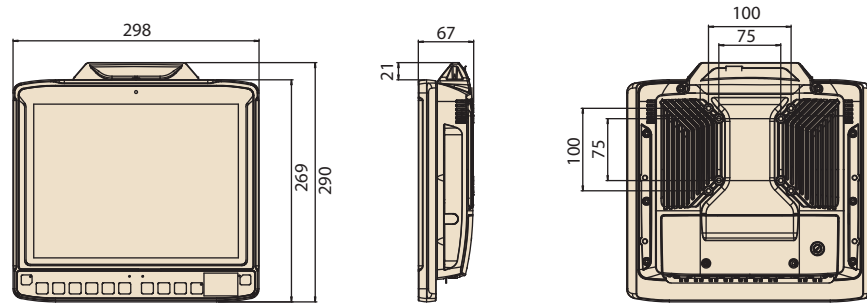

### DLT-V7312AP+

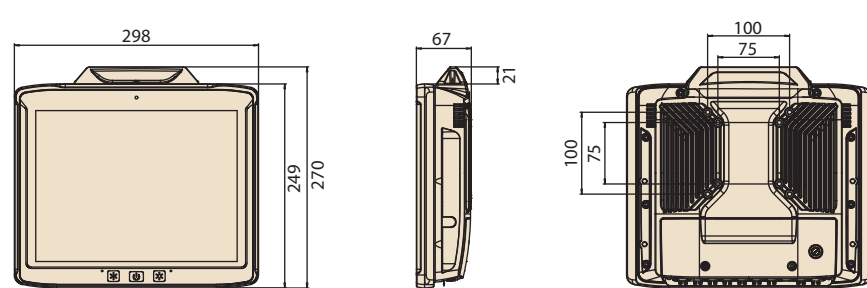

## I/O Connectors

